

A method and tool for Sustainability-driven Computer-Aided Process Planning with user-tuneable optimization

By Marko Chorbikj¹, Tommaso Turchi¹, Marco Cavallaro¹,
Fernando Gigante Valencia², María José Núñez Ariño²,
César Taboas Carrero³, César Martín Casado⁴

ABSTRACT:

This paper introduces the methodology framework, and a cloud-based Sustainability-driven Computer-Aided Process Planning (s-CAPP) tool aimed at optimizing efficiency and sustainability aspects of manufacturing operations at shopfloor level, considering a user-tailored optimization goal function. Geometric data extracted from 3D models of the parts to be produced are coupled with process parameters and resource consumption data from the manufacturing equipment in order to analyze the metrics for productivity and sustainability accordingly. By leveraging comprehensive data resources in manufacturing, s-CAPP allows companies to balance their production plans between productivity and sustainability through a user-friendly interface. Its application in a furniture manufacturing case study demonstrates its potential for process planning by prioritizing between productivity or sustainability, showcasing promising results. The presented s-CAPP implementation assists the production managers in taking decisions regarding sustainability and productivity in the production of batches through the prompting of intuitive visual results, impacting on both economic and environmental sides.

Keywords: sustainability-driven manufacturing, process planning, cloud-based computing, furniture manufacturing, process simulation, data-driven manufacturing, feature extraction

1. Introduction

The actual availability of information resources in the manufacturing environment triggers the opportunity to discern and manage these data to improve the efficiency of the production activities without losing sight of sustainability aspects related to both the manufacturing activities and the produced goods. Sustainability-driven process planning combines the design aspects of the elements to manufacture and the involved production processes to determine the granular operations to be applied to the pieces. This paper covers the introduction of a Sustainability-driven Process Planning tool (s-CAPP), the specification of the adopted solution, and the demonstration of its applicability in a production environment.

Traditionally, Computer-Aided Process Planning (CAPP) is a method of exploiting software within the process planning operations, in order to define the process

¹Department of Research & Development, Designo s.r.l., Milan, Italy.

²Department of Information Technology, AIDIMME Metal-Processing, Furniture, Wood and Packaging Technology Institute, Paterna, Valencia, Spain.

³Furniture Competence Center Industrial Manager. Royo Spain, Quart de Poblet, Valencia, Spain.

⁴Industrial Process Manager, Royo Spain, Quart de Poblet, Valencia, Spain.

steps required for the manufacture of a certain part in an automatic and reliable manner. As such, it can encompass a vast amount of interconnected technological areas ranging from computational geometry, manufacturing processes and their parameters, fixtures, tools, storage, and logistics options, making the design of an ideal CAPP software a task with an ever-increasing complexity. Within the EU-funded E2COMATION project - addressing the optimisation of energy usage at various stages of the manufacturing process - an innovative cloud-based s-CAPP solution was proposed with the purpose of mapping out the set of all possible production routes of a given part while characterizing their productivity and sustainability traits, so that an optimal one can be selected based on the user's prioritisation between productivity and sustainability. This paradigm enables the companies to determine its production in terms of productivity and sustainability, prioritizing according to particular business needs and factory conditions. It is complementary and can interact with Life Cycle Assessment (LCA) tools in order to increase accuracy in sustainability metrics and scheduling tools towards shop floor planning operations. It implements novel functions related to feature extraction and complexity analysis that provide feedback useful also for part design phase, it provides a new way to relate production with sustainability metrics via shop floor sensors and LCA data, and through a balancing slider included in the interface, give the user the ability to pick a prioritisation objective between productivity and sustainability. The proposed s-CAPP tool is an online solution that requires no local installation, and any potential automatic data exchange to complementary tools or interfaces is done through channels following the Message Queuing Telemetry Transport (MQTT) protocol, introduced by OASIS in 2013 and standardized in 2014 becoming a widely used communication protocol in the industry (Mishra et al., 2020).

In this paper, the s-CAPP approach is detailed, outlining its design and development strategies, as well as its application in an industrial case study in furniture manufacturing, showing promising results.

2. Related work

Due to the increase in the prices of fuel and electricity, the reduction in carbon footprint and energy consumption has become a necessity in the manufacturing sector. In this regard, advanced manufacturing solutions play a decisive role in Industry 4.0 (I4.0) environments, and in particular the Reconfigurable Manufacturing Systems (RMS), where the software and components of machines, or the material handling units can be added, removed, changed, or interchanged as needed, enabling to cope with changing requirements in an agile and cost-effectively manner (Yazdai et al., 2022).

Manufacturing is being strongly affected by sustainability issues and it is playing an important role in establishing a sustainable way ahead. Indeed, manufacturing is largely based on technology, which is asked, together with culture and economy, to provide tools and options for building new solutions towards a sustainable manufacturing concept (Garetti et al., 2012). Methods have been derived for improving the performance of manufacturing companies moving towards more sustainable practices. The traditional monitoring of the main classes of manufacturing attributes (cost, time, quality and flexibility) assesses the performance of a manufacturing system, but these attributes do not

take into consideration energy or resources efficiency that are key factors to sustainability. A sustainable production relies on the environmental friendliness of manufacturing plants and processes, which can be assessed through the energy consumption, water consumption, waste and emissions, health and safety of its workers, and even the sustainable performance of the whole supply chain. At process level there is a need to achieve optimized technological improvements for reducing the energy and resource consumptions and for improving the product life. Sustainable production can then be achieved from using more energy efficient processes (Salonitis et al., 2013).

The manufacturing sustainability can be measured in many ways: the energy and water consumption, the waste and emissions, and even the health and the safety of its employees among others (Saxena et al., 2020). The complexity and variety of factors determining the energy efficiency require intelligent systems for their optimization. (Fysikopoulos et al., 2015) proposes an architecture for the development of a decision support tool for sustainable value chain management, so stakeholders can be assisted in taking decisions to improve the energy use and the eco-efficiency of the whole or parts of the value chain. A framework for assessing the impact of decisions related to manufacturing operations considering the sustainable performance is presented by (Saxena et al., 2020). This enables the ranking of different production paths and supports the planning and scheduling of the production operations.

Regarding the product design, the modular approach plays an important role at the end of the product lifecycle, becoming an important means to realize design for remanufacturing. The remanufacturing characteristics of the produced goods during the phase of product design facilitates the reuse, upgrade and maintenance of products, easing its disassembly and recovery (Wang et al., 2014).

CAPP is part of the modern manufacturing pipeline. It aims at integrating the Computer-Aided Design (CAD) and Manufacturing (CAM) determining what parametrized processes are required to convert a block of material into a product, while the process planning involves the interpretation of design information to select and sequence the production of the piece, the choice of the appropriate machinery and parameters, and the final calculation of time and costs (Salehi et al., 2009). CAPP systems are complex, and their implementation requires very high investment, as well as an increased level of IT knowledge among the users and developers. There are only few evidence of complete CAPP implementation and integration of within the manufacturing systems available so far, especially in SMEs and craft manufacturing. The development of optimal and extensively used CAPP system is still a work in progress, and most of the main characteristics of Industry 4.0 (e.g., manipulation of big data, internet of things (IoT), cloud computing, etc.) can only enhance the faster development of the new automatized and digital process planning systems (Trstenjak et al., 2020). All these technologies have been widely reviewed by (Patil et al., 2020) and adopted in the industry. A Process-Planning framework for sustainable manufacturing is proposed by (Reiff et al., 2021), including ecological aspects, represented by carbon dioxide equivalents (CO₂-eq.). Such framework enables the modelling of production resources and part descriptions to calculate costs, ecological and time metrics for a specific part.

Traditionally, the process plans generated by the CAPP systems have not considered the real production conditions in the manufacturing plant. A detailed plan

should consider the processes, parameters, machinery, tools, and path of the items required for production. To this end, inputs such as the geometrical and dimensional features of the pieces to be manufactured, as well as materials, tolerances, and other related parameters, are required to elaborate an appropriate plan (Kumar et al., 2003). In additive manufacturing environments, for instance, the build orientation of parts has a relevant effect on the consumption of materials and energy. Therefore, the choice of a particular orientation from the range available when manufacturing a specific piece produces a significant economic and environmental impact. Innovative procedures have been presented to support the selection of optimal orientations that also consider LCA impact indicators (Mele et al., 2020). Moreover, manufacturing companies managing huge amounts of heterogeneous data may benefit from mature models to obtain an extensive roadmap for continuous improvement in some areas, assessing their strengths and weaknesses and moving towards an integrated data-driven manufacturing approach (Gökalp et al., 2021). The adaptation of such data-driven manufacturing models - including horizontal and vertical integration of the value chain and data management in the whole product life cycle - is required to beat the competition in the market. In this regard, previous research has focused on analysing and assessing reference I4.0 architectures to define maturity levels for data-driven manufacturing (Weber et al., 2017).

Moreover, geometrical constraints for manufacturing can be performed by Computer Aided Tolerancing (CAT) tools: in (Rosenqvist et al., 2014), the authors propose a geometry assurance process considering a CAT tool and a stability analysis that evaluates the assembly complexity and increases the geometrical robustness. In Computer Numerical Control (CNC) machining, (Bartoň et al., 2021) performs a geometric analysis of curvature-adapted machining, serving as an effective basis for tool positioning and motion planning that can be applied to free-form surfaces. This curvature analysis enables the design of collision-free motions and an accurate machining that reduces the milling paths and the machining time. Also, in the same vein, (Zhou et al., 2019) analyse the milling of face gears with a geometry study that calculates the envelope surface and evaluates the 3D modelling and curvature to prepare the tool paths.

Addressing manufacturability during the design or pre-design phases is another critical aspect of developing a CAPP tool. (Shukor et al., 2009) provides an overview of the Manufacturability Analysis Systems (MAS), evaluating the applicability of these systems to particular manufacturing processes. Also, (Molcho et al., 2008) describes a tool that addresses the manufacturability issue through a feature-based analysis system that evaluates the CAD model and captures the “know-how” in a structured manner, improving product timeliness and profitability. Manufacturability has also been considered in the ceramic industry by (Mayerhofer et al., 2021), which uses triangle-based mesh processing algorithms to detect features, lengths, and angles in the additive manufacturing scope. The method developed by (Ghadai et al., 2018) provides visual explanations of geometric features of 3D objects to evaluate the manufacturability of drilled holes, identifying what features are difficult to manufacture considering realistic CAD models.

The shift towards data-driven manufacturing, underscored by the deployment of sensor-based technologies, equips production systems with devices that capture shop floor data. Hence, manufacturing data collection and analysis have been studied and adopted in the modern manufacturing paradigm. The acquired data is interpreted into optimal

decisions to improve the production system in a closed-loop form. From the deployment of sensor-based technologies, modern production systems are equipped with devices that capture data on the shop floor, raising new challenges related to the management and reliability of these data (Xu et al., 2020). The reliability of the sustainability assessment requires a proper understanding of the underlying activities related to the different stages of the product life cycle. The emerging data-driven modelling approach complements and, in some cases, replaces the actual knowledge-based models based on physical behaviours (Li et al., 2017). Technical improvements at the manufacturing level, such as process planning optimisation and surface modification, are needed to reduce the consumption of energy and resources, as well as the toxic waste and related substances (Li et al., 2020). Our approach aligns with this aim, as outlined in the next section.

3. Methodology and architecture

The following sections describe the core methodology principles behind our approach and the underlying system architecture adopted for tool development.

3.1 Methodology framework

The main objective behind the s-CAPP approach described in this work is to provide a mechanism enabling a combined approach towards process planning, adopting a data-driven paradigm based on part's geometry for evaluating both productivity and sustainability aspects, so that process plans can be tuned towards satisfying either one or the other aspect, or any weighted combination of the two, as a matter of choice. In *Figure 1*, a block diagram of the core steps that constitute the methodology behind the s-CAPP approach are shown, consisting of the importing steps (in grey), the four functional steps (in blue) and the provided outputs (in yellow).

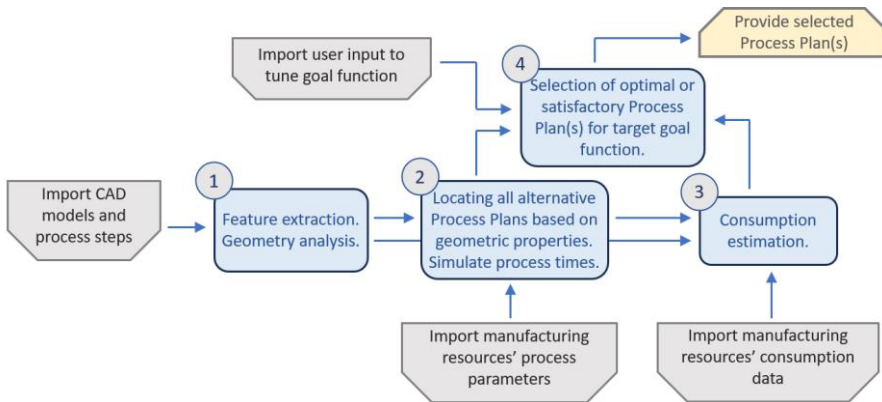

Figure 1: Block diagram of the s-CAPP methodology framework.

The methodology involves importing a digital 3D model of the part desired for production, accompanied by a list of process steps for each such model. The list of process

steps is required to cover the cases where not all product specifications affecting the choice of manufacturing processes, have their corresponding geometrical representation that can be extracted (e.g.: colouring, finishing, tolerances or surface treatment). The digital 3D model then undergoes a first a step of geometric analysis in order to extract features, other geometric data or metadata of interest. By cross-referencing these geometric properties to process parameters of machine resources (equipment) available to produce that part, in the following step 2, the s-CAPP constructs the set of all feasible process plans and simulates their respective process times. In the following step 3, a consumption estimation is done for all possible process plans. Such estimation can be based solely on the geometric parameters identified (arrow from step 1 to step 3), solely on the simulated process times for each manufacturing resource (arrow from step 2 to step 3), or any combination of the two. The choice of model used for estimating the consumption needs to be correlated to the data format of consumption data accordingly, e.g.: if the consumption is calculated based on geometric parameters, then the consumption data needs to be in the form of:

$$\frac{\textit{Consumed resource}}{\textit{geometric parameter}}$$

specified for each process and each manufacturing resource. Conversely, in the case of estimating consumption based on simulated process times, the suitable data format would be:

$$\frac{\textit{Consumed resource}}{\textit{process time}}$$

Steps 2 and 3 therefore provide metrics regarding the productivity (intended here as process time) and sustainability characteristics (intended as consumed resources) for the specific part-to-plant combination. Finally, in step 4, a goal function is constructed tuned according to user input and is used to select the process plans of interest. The goal function can be an optimising one, always resulting in the selection one ideal process plan, or it can be a condition goal function, that can result in none, one or a plurality of process plans (potentially ordered according to priority).

3.2 System architecture

To implement the described s-CAPP methodology, a system architecture has been adopted enabling the core functionalities as shown in *Figure 2*. In the following, a detailed description of the involved modules and the data flux between them is provided.

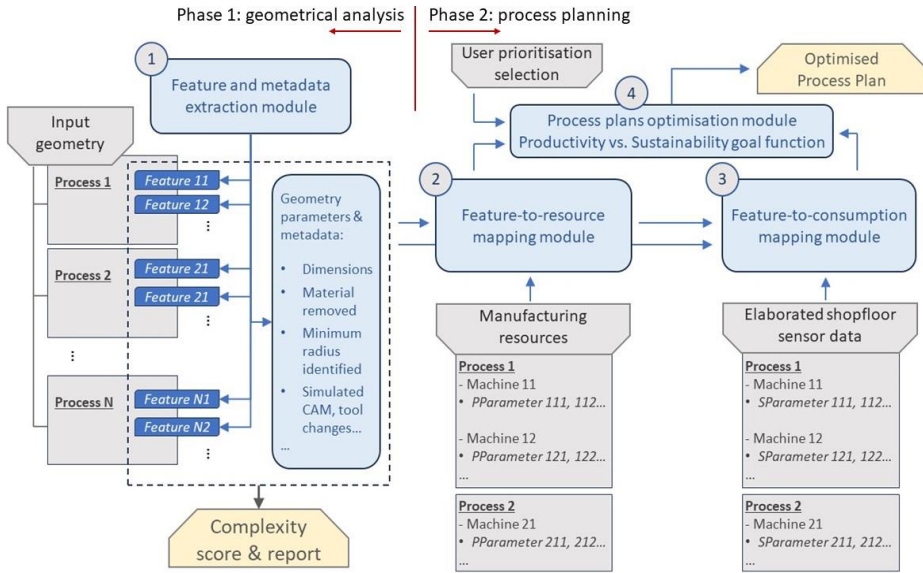

Figure 2: Overall architecture scheme of the s-CAPP approach, indicating inputs, data, functions and output.

The overall s-CAPP architecture is organized in two phases: a first phase focused on geometrical analysis and a second phase focused on production planning.

The first phase requires the upload of part geometries in the form of a digital CAD file and their required processes and runs the Feature and metadata extraction module. The core functionality behind this module is to perform a geometrical analysis of the uploaded parts to extract useful geometrical data, metadata or features, categorised per specific process stage. These features are not process exclusive, thus $Feature_{ik}$ can also represent $Feature_{jl}$, therefore being considered both for process i and process j , one such feature example being perimeter extraction that is relevant for both cutting and edge banding operations. The adopted methodology and criteria for the step of feature extraction can vary greatly between general primitive shape extraction methods for manufacturing (e.g. holes or pockets) (Abouel Nasr et al., 2006) to a process, plant or topic specific features (Viejo et al., 2012). In addition to the feature extraction, the first phase also provides metadata information relevant to both productivity and sustainability aspects (e.g., dimensions, simulated CAM length and number of tool changes for a standard cartesian machine, minimum concave radius for tool selection or material removed from the rough stock geometry).

In the adopted architecture, the first phase uses this extracted geometrical data to generate an auxiliary output concerning the complexity of the part. Namely, the extracted geometrical data can be used to construct a report of identified features per process and can further implement a quantitative model that generates in output a single numerical value, without unit, indicative of the complexity of the part. To describe the concept through an example: a part with a lower number of identified through holes can be considered less complex than a part with a higher number of identified through holes, if

both can be processed with drilling. In another example, the lack of geometrical features requiring a specific manufacturing process (the lack of features to mill), can lower the complexity score of a given part. This is illustrated in *Figure 3* where Part A with dimensions 600 mm. by 220 mm. by 8 mm. has resulted in a total complexity score of 186, with 49, 131 and 6 being the scores for perimeter, drilling and milling respectively. Part B, with dimensions of 240 mm. by 40 mm. by 12 mm. has, on the other hand, resulted in a total complexity score of 25, with 17, 8 and 0 being the scores for perimeter, drilling and milling respectively. In this example, the difference in milling score is due to the presence of a slot in PartA, a feature that has been associated to a milling process within the s-CAPP tool.

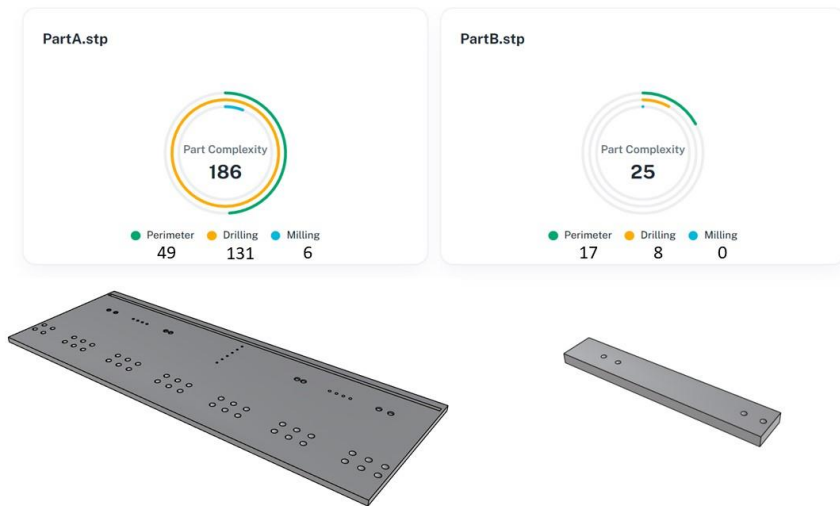

Figure 3: Comparison between part complexity scores.

The model can be tuned to also provide in output a normalized value with respect to a given reference part. It should be noted that the auxiliary output aimed at part complexity analysis included in the adopted architecture is not involved in the methodology block diagram in *Figure 1*, since it is not necessary for reaching the main objective behind the s-CAPP approach as a user-tuned process planning platform.

The second phase requires as one input, a list of manufacturing resources per process, with their respective process parameters $PP_{parameter}_{wyz}$ (e.g., workspace, process feed, tool availability, number of simultaneous active tools or feature specific functionalities, like side drilling capability within drilling machines category). It then implements the Feature-to-resource mapping module that considers previously obtained geometric data, metadata and features extracted per process, and maps them, wherever possible, to the manufacturing resources available for the respective processes. This enables for the creation of a matrix representing all possible part production routes, simulating the required time for all possible feature-to-resource combinations. To evaluate

the sustainability metrics, an additional input required is a list of consumption values $SParameter_{wyz}$ (e.g., electrical energy, compressed or suction air, water consumption), measured per manufacturing resource and for each process, directly from the shopfloor. Such measured data is matched to a past production schedule in order to generate reliable consumption data in the correct format based on the adopted estimation model, as discussed in section 3.1. Finally, the tool provides the user with the possibility to select different levels of prioritisation between sustainability and productivity, through a slider within the user interface. This in turn defines the weights within the goal function of the s-CAPP tool, providing in output the single most optimal, the first n optimal production plans, or an ordered list of all production plans, according to the user's priority objective. Such plans can then be used downstream for scheduling operations.

The split of the proposed system architecture in a first phase aimed at geometrical analysis and a second phase aimed at process planning, albeit not strictly necessary, divides the functional operations in two conceptually different groups: the former aimed solely at the geometrical shape of the part to be produced, while the latter introduces the aspect of the production plant available to produce such part. In this way, the proposed approach serves as a platform for analysing productivity and sustainability metrics for a specific part-to-plant combination.

4. Industrial application

The following sections describe the pilot industrial application and how the solution has been adopted and experimented.

4.1 Case study in the furniture industry

The case study for the application of the solution is represented by ROYO Group, company founded in Valencia (Spain), which is the third largest European group in the bathroom furniture and shower equipment manufacturing sector, with approximately 900 employees in its plants and producing more than one million pieces of furniture per year in an international consolidation phase. The company mainly produces finished goods and semi-finished items.

The production plan is performed on a daily basis for two weeks ahead, and the company manages two approaches: the make-to-order (the Enterprise Resource Planning (ERP) generated the direct order) and the make-to-stock approach (the operator keeps a defined minimum stock by monitoring the quantities in the warehouse). The *Figure 4* below shows a sample design used in the furniture manufacturing environment of the presented case study.

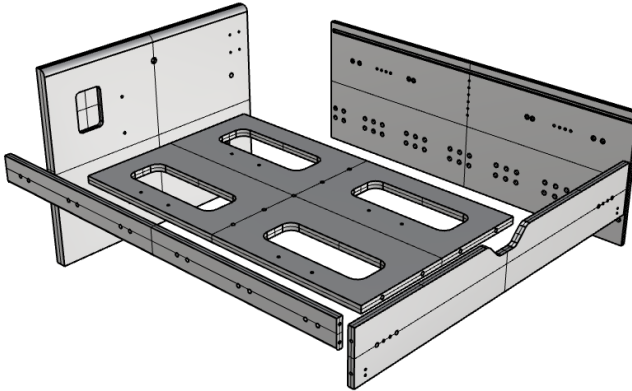

Figure 4: Example parts' design for the furniture industry.

The production information is organized in weekly meetings involving the different plant managers to take decisions for the following week. Therefore, each machine gets a mapping depending on the type of machine and the expected production: the automatic equipment gets the information from a default program loaded in the system and generated by the technical office, while in the manual machines the operator manually selects a program from a predefined list. This means that, at this point, the production processes were not considering the specific geometry of the pieces and the required related machinery to address its production. Therefore, the use of the proposed s-CAPP solution is necessary to get the required awareness about the production capacities and perform the balancing between productivity and sustainability.

It should be noted that real machine data, process parameters, consumption data and part designs belonging to ROYO Group have been modified for confidentiality purposes.

4.2 Application of the solution in the production environment

An s-CAPP tool following the methodology and architecture as described in Chapter 3 can be designed, developed and applied to a real case, following a setup dedicated for a specific manufacturing plant, process stages and manufacturing resources with corresponding productivity and consumption parameters. In this section we will describe one such tool embodiment in the form of a cloud-based web application where the user can access the tool via a browser using login credentials. The tool requires no local installation and consists in a user-interface that serves to collect input data, transmit them to a cloud-based software and provide results from the analysis back to the user.

The adoption of the solution requires an initial step of setup to concretise the tool for a specific production plant. This includes generating a list of manufacturing resources available per process stage, with corresponding productivity and consumption parameters for each such manufacturing resource. Any potential plant or company specific feature-to-resource mapping or selection logic, part complexity estimation model or particular file

formats should be addressed in the setup phase. These inputs are required to model the current, as-is state of the production plant and related manufacturing know-how.

The *Figure 5* below represents a user interaction diagram with the tool. Each numbered arrow 1-5 represents information exchange step between the user and the tool, in a chronological order. The tool interaction takes place through four distinct screens (tabs).

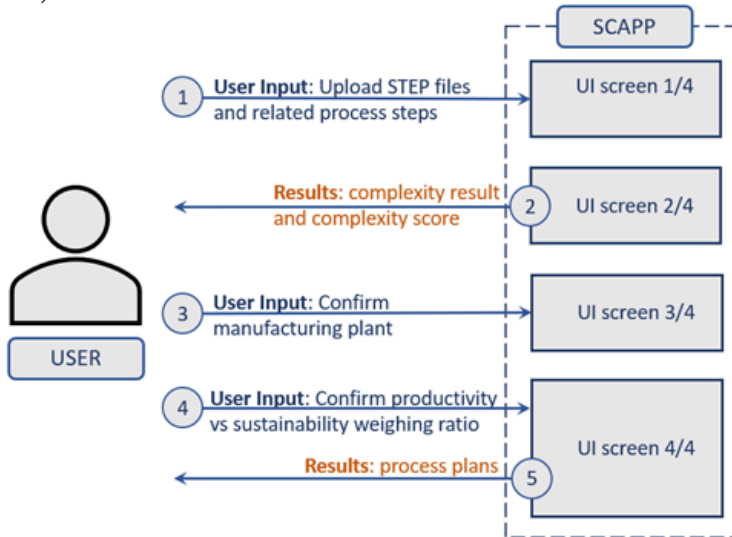

Figure 5: Diagram of interaction of the user with the s-CAPP tool.

In step 1, the user is required to provide digital part designs of interest in the form of STandard for the Exchange of Product model data (STEP) files, the ISO10303 standard that provides mechanisms for Geometry Data Exchange, concerned with the transfer of product shape models, assembly structure, and configuration control information (ISO, 2024). One or multiple, closed, single body geometries can be uploaded to the tool for processing in any position and orientation. Additional required input when running the tool is the information reflecting the processes (e.g., cutting, edge banding, drilling, milling, lining, lacquering) required to produce the piece. In step 2, the tool displays the results obtained from the part complexity analysis. In this specific tool embodiment, the part complexity model consists of three separate parameters:

Part Complex. = Perimeter Complex. + Drilling Complex. + Milling Complex.

The Part Complexity result is represented through an a-dimensional, integer number, shown in the centre of each radial graph corresponding to each uploaded part. The Perimeter, Drilling and Milling complexity are indicated visually through infill of the radial graphs with pre-defined maximum values in different colours, as can be seen in *Figure 6*. In Step 3, the user is shown the model of the production plant with a list of manufacturing resources per process stage, each with their respective productivity and consumption parameters. In this step, the user can optionally modify the production plant parameters to better estimate the actual or simulated plant state. The required input is a confirmation of the final production plant model, as can be seen in *Figure 8*. In Step 4, the user is presented with a slider that allows selecting the goal function preference to be considered for the process plans, which in turn affects the weights assigned to productivity

and sustainability metrics within the optimisation function. This is shown in *Figure 7*. After analysing all possible manufacturing routes and analysing their productivity and sustainability scores, in Step 5, the tool provides the user with optimal process plans based on the user's selection done in the previous step. The process plans are provided in the format of a .CSV file where each row represents a part to be manufactured. Only one manufacturing resource per process stage is selected as the optimal choice for manufacturing the specific part and the user selected goal function. This is noted by providing a non-zero number indicative of the effective manufacturing time in seconds in the column of the manufacturing resource selected as the optimal one by the s-CAPP tool. If an entire process stage has only zero values for a given part, it indicates that the part has no need to be passed through said process stage. In *Figure 9*, example process plans of seven different parts are shown for a production plant that has a cutting, lining, edge banding, drilling, milling and lacquering stage with 3, 2, 4, 5, 2 and 2 manufacturing resources respectively.

The adoption of the solution in the production environment can be beneficial in different circumstances, product phases and plant usage. The following scenarios are foreseen:

Analysis of the geometrical complexity: in this case, the user (e.g., product designer) uploads the parts designs to the tool and runs the geometrical and manufacturing complexity analysis, generating a complexity report. This scenario enables the application of feature extraction algorithms to analyse the different parts of the model estimating the manufacturing complexity of the piece and through an automated process of feature and metadata extraction, provide useful insight for the product design phase. Extracted geometrical data can also be treated as an input to an LCA tool related to the same plant, due to its unique capacity to relate production and consumption data to geometrical features or FU. This would require the step of matching production, geometrical and consumption data in a synchronous way. The *Figure 6* below illustrates the analysis of the complexity conducted by the tool.

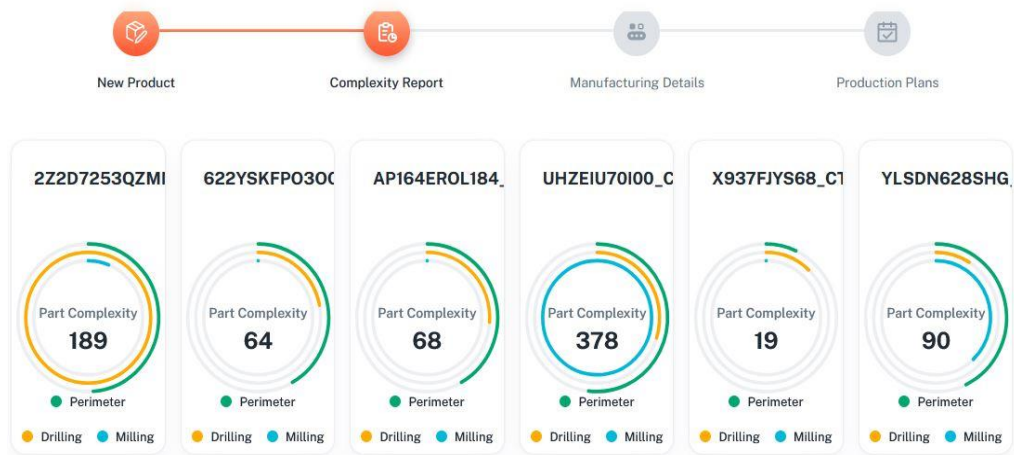

Figure 6: Complexity analysis result generated by the s-CAPP tool.

When proceeding to the complexity report page, the user is presented with numerical scores for each of the uploaded parts and the possibility to download a report in the form of a document containing detailed features and metadata information. The above geometrical complexity scenario only involves using the first phase of the tool.

Generation of the process plan: in this scenario, the user (e.g., production manager) goes through the geometrical analysis phase like in the previous case, with the additional step of proceeding through the second phase aimed at generating production plans. Here, the user confirms the suggested production configuration in terms of manufacturing resources (already tuned s-CAPP tool for the specific production plant) and proceeds to select the desired objective preference (sustainability vs productivity).

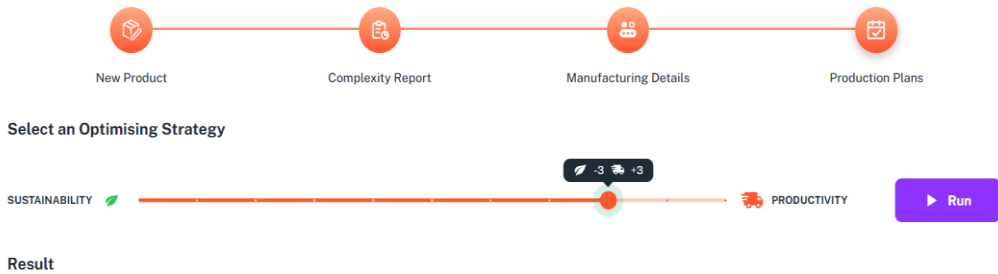

Figure 7: Goal function slider, here shown in the position of 20-80 distribution between sustainability and productivity.

This is enabled by the slider position choice, thus indicating the goal preference to be considered when deciding for the optimal process plan, as depicted in Figure 7 above. A file containing the optimal process plan is then generated by the tool.

Simulation of the production plan: in this case, the user would proceed through the geometry analysis phase first and then proceed to process planning but introduce a modification in the suggested list of manufacturing resources. This can be achieved by adding new or removing existing manufacturing resources or modifying their parameters. This scenario serves the purpose of simulating process plans in case of a modification of the available manufacturing resources (e.g., a machine is down for maintenance, adopts new process parameters, or a new machine is available). The Figure 8 below shows an excerpt of the list of production resources (e.g., machinery) used to perform the simulation scenarios, also illustrating the addition of a new drilling machine.

Drilling										
Machine Name	Workspace Width	Workspace Length	Speed	Tools	Drill from Side	Electric Energy / FU	Compressed Air / ...	Suction Air / FU	Rem...	
Drill Mach 1	3,200 mm	1,880 mm	4 m/min	4	✓	0.079 kw	0.294 m³	0.345 m³		
Drill Mach 2	2,240 mm	1,220 mm	7 m/min	2	✗	0.366 kw	0.861 m³	0.413 m³		
Drill Mach 3	2,160 mm	1,800 mm	5 m/min	4	✗	0.388 kw	1.567 m³	1.223 m³		
Drill Mach 4	2,800 mm	2,400 mm	5 m/min	6	✓	0.053 kw	1.066 m³	0.113 m³		
Drill Mach 5	1,800 mm	320 mm	8 m/min	1	✗	1.819 kw	1.116 m³	0.016 m³		
New Drilling Machine	0 mm	0 mm	0 m/min	0	✗	0 kw	0 m³	0 m³		+

Milling										
Machine Name	Workspace Width	Workspace Length	Speed	Tool Diameter	Electric Energy / FU	Compressed Air / FU	Suction Air / FU	Rem...		

Figure 8: Editing manufacturing resources for simulating what-if scenarios.

Generated process plans contain the optimal process planning per part, by selecting the most suitable manufacturing resource per process stage. Each row is representative of one such part, with numbers indicating effective manufacturing time in seconds, populating the cells of the optimal route only.

In Figure 9 below, two process plans can be noted, generated for the same part geometries and same manufacturing resources, but with contrasting goal functions: top one aimed at optimising for productivity, the bottom one aimed at optimising for sustainability.

	A	B	C	D	E	F	G	H	I	J	K	L	M	N	O	P	Q	R	S	
1	Filename	CutMach1	CutMach2	CutMach3	LiningLine1	LiningLine2	EdgeMach1	EdgeMach2	EdgeMach3	EdgeMach4	DrillMach1	DrillMach2	DrillMach3	DrillMach4	DrillMach5	CNC1	CNC2	LacqLine1	LacqLine2	
2	22ZD7253Q2M	0	3.075	0	0	0	0	1.2858	0	0	0	0	0	0	0	8.1	9.2934	0	0	3
3	62ZY5KFP03OC	0	2.6022	0	0	0	0	0.1824	0	0	0	0	0	0	2.88	0	0	0	0	0
4	AP16AEROL1B4	0	2.6286	0	0	0	0	0.0966	0	0	0	0	0	0	3.84	0	0	0	0	0
5	UHZEIU70100_1	0	0	3.969	0	17.2002	0	0	0	0	0	0	0	0	3.84	0	18.5292	0	0	2.7
6	X937FJY568_CT	0	0.4452	0	0	0	0	0	0	0	0	0	0	0	0	0.3	1.935	0	0	0
7	Y1SDN628SHG_	0	0	3.2772	0	14.2002	0	0.6858	0	0	0	1.5426	0	0	0	0	28.7322	0	0	0

	A	B	C	D	E	F	G	H	I	J	K	L	M	N	O	P	Q	R	S
1	Filename	CutMach1	CutMach2	CutMach3	LiningLine1	LiningLine2	EdgeMach1	EdgeMach2	EdgeMach3	EdgeMach4	DrillMach1	DrillMach2	DrillMach3	DrillMach4	DrillMach5	CNC1	CNC2	LacqLine1	LacqLine2
2	22ZD7253Q2M	4.92	0	0	0	0	0	0	0	4.5	16.2	0	0	0	0	0	12.3912	5.1426	0
3	62ZY5KFP03OC	4.1634	0	0	0	0	0	0	0	0.6378	3.6	0	0	0	0	0	0	0	5.1426
4	AP16AEROL1B4	4.206	0	0	0	0	0	0	0	0.3378	4.8	0	0	0	0	0	0	0	0
5	UHZEIU70100_1	0	0	3.969	25.8	0	0	0	0	0	4.8	0	0	0	0	0	24.7056	4.6284	0
6	X937FJY568_CT	0.7128	0	0	0	0	0	0	0	0	0.6	0	0	0	0	0	0	2.58	0
7	Y1SDN628SHG_	0	0	3.2772	21.3	0	0	0	0	2.4	2.7	0	0	0	0	0	38.31	0	0

Figure 9: Generated production plans generated by the s-CAPP tool, aimed fully at optimising productivity (top) and sustainability (bottom).

The s-CAPP tool has been deployed and configured in the woodworking industry domain represented by the ROYO Group as furniture manufacturer in this case study. At this point, the benefits for the industrial side of this applicability must be emphasized. These benefits cover relevant aspects such as the efficiency, the overall time saving, or the friendliness of the system deployed to obtain these advantages.

Both, the automation of the analysis of CAD models and the generation of production plans enhances the production planning efficiency, by reducing the time and the effort required for such analysis, considering that the CAD analysis used to be estimated by simple visual observation prior to introducing the tool.

The uploading and analysis of multiple STEP files simultaneously allows the concurrent handling of data volumes, which widely improves the traditional method. This batch processing capability also saves time dedicated to the production planning. Additionally, the low response time of the tool allows users to generate and download the analysis reports and the production plans in a short time. The accuracy of the complexity analysis ensures that production plans are based on reliable data, by minimizing potential errors and improving the overall efficiency of the production process.

Overall, the s-CAPP tool presents a user-friendly interface that makes the tool accessible for users even with low technical production expertise, with a reduced learning curve that accelerates the adoption of the tool within the company. The tool generates comprehensive documentation (e.g., geometrical and complexity reports) that can be used for process review, product (re)design, audits, and the continuous improvement of the production processes.

The calculation of the complexity score becomes particularly relevant, so this is an a-dimensional numeric value that defines the complexity of the parts considered for manufacturing. This score is essentially the sum of the corresponding scores for circular features, non-circular, and perimeter. The point to be emphasised in this regard is the capability to adapt these calculations based on the singularities of the manufacturer, regarding both geometry and production.

The balancing slider provided by the interface is, in the end, the most substantial functionality provided by the tool, as it allows production managers to establish a harmony level between the productivity and the sustainability during the production processes. The clean presentation of this function simplifies its use hiding the specific considerations and calculations happening behind the scenes, which, nevertheless, can be altered based on the particularities of the company (e.g., machinery and production-related resources). This slider functionality allows the manufacturer to accommodate for different needs of prioritization (Productivity vs Sustainability) at plant level based on the production demands which may change over certain times of the year.

Another aspect worth highlighting is the capability to simulate special scenarios through the tool. This is particularly useful when the manufacturer needs to analyse the effect of some new conditions (e.g., addition of new machines, introduction of maintenance periods) on the production plan.

5. Conclusion

In this work, a general methodological framework is shown for a sustainability-driven process planning platform where productivity and sustainability metrics can be analysed and prioritized according to user's choice. The development of a s-CAPP tool with the adopted architecture is also presented, as well as its industrial applicability through a case study focused on the manufacturing of specific pieces in the furniture industry. An overview of practical user scenarios is provided to describe the utility and potential of the tool for added value in an industrial context. The most significant limitations, concluding remarks and forthcoming activities are described in more detail below.

5.1 Limitations

One limitation inherently present in the methodology and architecture described in this work, is the assumption that the productivity and sustainability metrics represent somewhat opposing (or at least different) optimisation problems. However, it is possible that the output that optimises productivity coincides with the output that optimises sustainability, leading to low or minimal variability of output. To further illustrate this point, let us consider a process of thermal treatment of a part using manufacturing resource (e.g.: electric oven) with heated chamber dimensions much larger than the part itself. Let us also assume that the said thermal process is conducted by maintaining the part at 460K degrees for 40mins. In such a case, it is plausible that the manufacturing process consumes a very similar quantity of resources (e.g.: electricity) both in the cases where only one part is being treated, or multiple parts have been loaded into the heated chamber of the electric oven, thus undergoing the same thermal manufacturing process at the same time with little effect on the total electricity consumption. Therefore, isolating the thermal manufacturing process alone, a scenario is reached where the productivity can be drastically increased (from single to multiple parts) by little to no variation on the total consumed resources. Furthermore, if the sustainability is defined as a metric per part produced, a scenario is reached where increased productivity leads to improved sustainability (less resources consumed per part), thus having an alignment between the two optimisation problems, a conclusion potentially valid at least up to the number of pieces that can fit inside the heated chamber, after which a new batch would need to be initiated. The concept here exemplified through a batch-based production, can have an analogous implication in other manufacturing processes or situations of auxiliary consumption of resources required for an operational production plant, in other words, scenarios where the total consumption is not directly or strongly dependent to the number of parts produced. It is assumed that the extent up to which this limitation is effective depends on the application and the definition of the goal function.

Another limitation is that the initial tool setup and efficient use of the presented solution requires a deep knowledge of the manufacturing processes in the industrial company and the availability of rich manufacturing data and corresponding resource consumption data, which is not always practically available. The gathering of production data from the industrial companies is often a demanding task, often due to the fact that the information required for the setup of the tool is neither centralized nor easily accessible. In the presented use case, shopfloor information regarding machinery and production processes was collected and provided by the industrial partner, including the processes and related parameters (e.g., cutting, lining, drilling, milling, etc.), and the characterisation of the machines through relevant properties (e.g., dimensions of workplaces, speed, power consumption, etc.). Even if some of this information is available in technical data sheets, it still needs to be collected, adjusted to real practical manufacturing conditions and formatted to be submitted to the tool, which often means a significant effort. In such cases, the elaboration of data templates to be fulfilled by technicians from both the industrial and the tool development side, in a collaborative way, becomes enormously useful, as this dramatically speeds up the gathering process and the setup time of the tool. The s-CAPP can operate while accepting process, equipment or consumption data with different frequency, varying from one-time setup configuration to

continuous updates. In cases where the production plant information is managed by internal data acquisition and elaboration systems in the industrial partner, dedicated scripts can be implemented to automatically export sensor data and elaborated production information to the format accepted by the s-CAPP. The choice of updating input data with a certain frequency would also depend on the volume of equipment or process information to be considered by the tool, for example higher frequency being preferable when this is a large volume.

Finally, the utility of this tool appears to be higher when the design of the pieces to manufacture becomes more complex and with higher variability. To further clarify this aspect, it can be assumed that the s-CAPP tool is tuned for a production plant with seven distinct process stages such as: cutting, stacking, edge banding, drilling, milling, painting and surface finish. If the aim were to use such a production plant to produce parts that are relatively monotonous in geometrical design and relatively simple according to our definition of complexity in Section 3.1, it is expected that the output generated by the s-CAPP (intended either in terms of process plans sequence selection and relative difference to other process plans from the pool of possible ones, or total final estimation of productivity and consumption parameters), will have a more restricted range of variability. For example, let us further assume the above production plant is facing a production request for parts with similar dimension and a limited number of geometrical features and therefore process requirements, (refer to PartB in *Figure 3*) it is expected that the s-CAPP selects very similar process plans for all parts, resulting thus in a lower need to run the tool when new parts of the same nature get introduced. Therefore, the authors assume that the utility of the proposed s-CAPP tool is, to some extent, directly linked to the design and manufacturing complexity of the parts provided in input, as well as the difference between the plant's capacity to apply manufacturing processes and the part's needs for those processes (underutilisation of production plant). An additional aspect we assume takes place is that of the utility the tool can provide with respect to the user: while the selection of the appropriate machines for a given part can be intuitive for a person experienced in the manufacturing processes, such decisions might be harder to do on many parts, with varying part design and high variable manufacturing complexity. Further analyses are required to better understand all factors that can limit the operational workspace of the s-CAPP tool and thus the range of generated output.

5.2 Future work

The methodology and architecture presented here can be extended with additional functionalities of closely related research topics, such as Life Cycle Assessment. Namely, the s-CAPP tool has the inherent capacity to automatically relate geometry data from the part to be produced, to both productivity and sustainability aspects of a set of manufacturing processes. As such, it can be used as an integrated part of a more detailed analysis where consumption or production is to be related to geometrical features, or Functional Units, significant in a holistic environmental impact analysis on either production plant or product level. In one example briefly introduced above in Chapter 4.2, the s-CAPP tool can be used to post-process synchronised production data and consumption data, and provide it expressed in terms of a specific geometrical metrics, such as: effective metres of edges cut or edge banded, number of holes drilled, metres squared

lacquered or volume of material removed, since such data is already available for the objective of process planning. Therefore, given in input production data (digital models of parts and their respective number of units produced) synchronised with consumption data describing the resources spent to produce said batches, the s-CAPP tool can provide for a new level of data elaboration by providing relations to specific geometric features. Such data could also, in a subsequent stage, provide for a valuable input to an LCA tool for both internal plant assessment or product certification in terms of environmental impact, whether such studies would be aimed at existing or past production scenarios, or the simulation of new ones (e.g.: introducing a new product). Due to this close relationship, the authors believe that further enhancing the s-CAPP architecture with Life Cycle Assessment concepts or merging these separate solutions into a holistic digital pipeline with synchronised data flux, could provide for an interesting topic of further developments.

Acknowledgment: Partially supported by the European Commission through the H2020 Framework Programme, Innovation Actions (IA), and the Life-cycle optimisation of industrial energy efficiency by a distributed control and decision-making automation platform (E2COMATION) project through Grant 958410.

References

- Abouel Nasr, E. S., Kamrani, A. K. (2006). A new methodology for extracting manufacturing features from CAD system, *Computers & Industrial Engineering*, Volume 51, Issue 3, pp. 389-415. DOI: <https://doi.org/10.1016/j.cie.2006.08.004>
- Bartoň, M., Bizzarri, M., Rist, F., Sliusarenko, O, Pottmann, H. (2021). Geometry and tool motion planning for curvature adapted CNC machining. *ACM Trans. Graph.* 40, 4, Article 180.
- Fleischer, G., Schmidt, WP. Functional unit for systems using natural raw materials. (1996) *Int. J. LCA* 1, 23–27.
- Fysikopoulos, A, Alexopoulos, T, Pastras, G, Stavropoulos, P, & Chrissoulouris, G. (2016). On the Design of a Sustainable Production Line: The MetaCAM Tool. *Advances in Multidisciplinary Engineering*, Volume 15. DOI: https://doi.org/10.1115/1.861080_ch14
- Garetti M., Taisch M. (2012). Sustainable manufacturing: trends and research challenges. *Production Planning & Control*, Volume 23, 83-104. DOI: <https://doi.org/10.1080/09537287.2011.591619>
- Ghadai, S., Balu, A., Sarkar, S., Krishnamurthy, A. (2018). Learning localized features in 3D CAD models for manufacturability analysis of drilled holes, *Computer Aided Geometric Design*, Volume 62, 263-275. DOI: <https://doi.org/10.1016/j.cagd.2018.03.024>
- Gökalp, M. O., Gökalp, E., Kayabay, K., Koçyiğit, A., P. Eren, P. E. (2021). Data-driven manufacturing: An assessment model for data science maturity. In: *Journal of Manufacturing Systems*, Volume 60, 527-546. DOI: <https://doi.org/10.1016/j.jmsy.2021.07.011>
- International Organization for Standardization [ISO] (2024) ISO 10303-1:2024 Industrial automation systems and integration — Product data representation and exchange — Part 1: Overview and fundamental principles, ISO.
- Kumar, M., Rajotia, S. (2003). Integration of scheduling with computer aided process planning, *Journal of Materials Processing Technology*, Volume 138 1–3, pp. 297-300. DOI: [https://doi.org/10.1016/S0924-0136\(03\)00088-8](https://doi.org/10.1016/S0924-0136(03)00088-8)
- Li, L., Qu, T., Liu, Y., Zhong, R.Y., Xu, G., Sun, H., Gao, Y., Lei, B., Mao, C., Pan, Y. and Wang, F. (2020). Sustainability Assessment of Intelligent Manufacturing Supported by Digital Twin. In: *IEEE Access*, vol. 8, pp. 174988-175008.

- Li, Y., Zhang, H., Roy, U. and Tina Lee, Y. (2017). A data-driven approach for improving sustainability assessment in advanced manufacturing. In: 2017 IEEE International Conference on Big Data (Big Data), Boston, MA, USA, pp. 1736-1745.
- Mayerhofer, M., Lepuschitz, W., Hoebert, T., Merdan, M., Schwentenwein, M., Strasser, T. I. (2021). Knowledge-Driven Manufacturability Analysis for Additive Manufacturing. In IEEE Open Journal of the Industrial Electronics Society, Volume 2, pp. 207-223. DOI: 10.1109/OJIES.2021.3061610
- Mele, M., Campana, G. (2020). Sustainability-driven multi-objective evolutionary orienting in additive manufacturing. In: Sustainable Production and Consumption, Volume 23, pp. 138-147. DOI: <https://doi.org/10.1016/j.spc.2020.05.004>
- Mishra, B., Kertesz, A. The Use of MQTT in M2M and IoT Systems: A Survey. (2020). In IEEE Access, Volume 8, pp. 201071-201086.
- Molcho, G., Zipori, Y., Schneor, R., Rosen, O., Goldstein, D., Shpitalni, M. (2008). Computer aided manufacturability analysis: Closing the knowledge gap between the designer and the manufacturer, CIRP Annals, Volume 57, Issue 1, pp. 153-158. DOI: <https://doi.org/10.1016/j.cirp.2008.03.046>
- Patil, R., Thikane, S. J. (2020). A comprehensive review of Digital Manufacturing. Journals of Mechatronics Machine Design and Manufacturing, Volume 2, 1, pp. 1-11.
- Reiff, C., Buser, M., Betten, T., Onuseit, V., Hossfeld, M., Wehner, D., Riedel, O. (2021). A Process-Planning Framework for Sustainable Manufacturing. Energies. DOI: 10.3390/en14185811
- Rosenqvist, M., Falck, A.C., Lindkvist L., Söderberg, R. (2014). Geometrical Robustness Analysis Considering Manual Assembly Complexity, Procedia CIRP, Volume 23, pp. 98-103. DOI: <https://doi.org/10.1016/j.procir.2014.10.072>
- Salehi, M., Tavakkoli-Moghaddam, R. (2009). Application of genetic algorithm to computer-aided process planning in preliminary and detailed planning, Engineering Applications of Artificial Intelligence, Volume 22, 8, pp. 1179-1187. DOI: <https://doi.org/10.1016/j.engappai.2009.04.005>
- Salonitis, K., Stavropoulos, P. (2013). On the Integration of the CAx Systems Towards Sustainable Production. Procedia CIRP. 9. 115-120. DOI: 10.1016/j.procir.2013.06.178
- Saxena, P., Stavropoulos, P., Kechagias, J., Salonitis, K. (2020). Sustainability Assessment for Manufacturing Operations. Energies. 13, no. 11. DOI: 10.3390/en13112730.
- Shukor, S.A., Axinte, D.A. (2009). Manufacturability analysis system: issues and future trends, International Journal of Production Research, 47:5, 1369-1390.
- Trstenjak, M., Opetuk, T., Cajner, H., Tosanovic, N. (2020). Process Planning in Industry 4.0 - Current State, Potential and Management of Transformation. Sustainability. 12. 5878. DOI: <https://doi.org/10.3390/su12155878>
- Viejo, D., Rodríguez, J., Cazorla, M., Gil, D., Johnsson, M. (2012). Using GNG to improve 3D feature extraction-Application to 6DoF egomotion. Neural networks: the official journal of the International Neural Network Society, vol 32, pp 138-46. DOI: 10.1016/j.neunet.2012.02.014.
- Wang, P., Liu, Y., Ong S.K., Nee A. (2014). Modular Design of Machine Tools to Facilitate Design for Disassembly and Remanufacturing, Procedia CIRP, Volume 15. Pages 443-448. DOI: <https://doi.org/10.1016/j.procir.2014.06.085>
- Weber, C., Königsberger, J., Kassner L., Mitschang, B. (2017). M2DDM – A Maturity Model for Data-Driven Manufacturing. In: Procedia CIRP, Volume 63, pp. 173-178. DOI: <https://doi.org/10.1016/j.procir.2017.03.309>
- Xu, K., Li, Y., Liu, C., Liu, X., Hao, X., Gao, J. and Maropoulos, P.G., (2020). Advanced Data Collection and Analysis in Data-Driven Manufacturing Process. Chinese Journal of Mechanical Engineering, Volume 33, 43.
- Yazdani, M., Khezri, A., Benyoucef, L. (2022). Process and production planning for sustainable reconfigurable manufacturing systems (SRMS): multi-objective exact and heuristic-based approaches. The International Journal of Advanced Manufacturing Technology. 119. DOI: 10.1007/s00170-021-08409-0.
- Zhou, Y., Wang, S., Wang, L., Tang, J., C. Chen, Z. (2019). CNC milling of face gears with a novel geometric analysis, Mechanism and Machine Theory, Volume 139, pp 46-65. DOI: <https://doi.org/10.1016/j.mechmachtheory.2019.04.009>